

**Adjustable Keyboard Pad
(AKPM/VAKF/VAKL series)**
Installation Instructions

**Plataforma ajustable para teclado
(Serie AKPM/VAKF/VAKL)**
Instrucciones de instalación

**Plateau clavier réglable
(série AKPM/VAKF/VAKL)**
Instructions d'installation

Tools Required

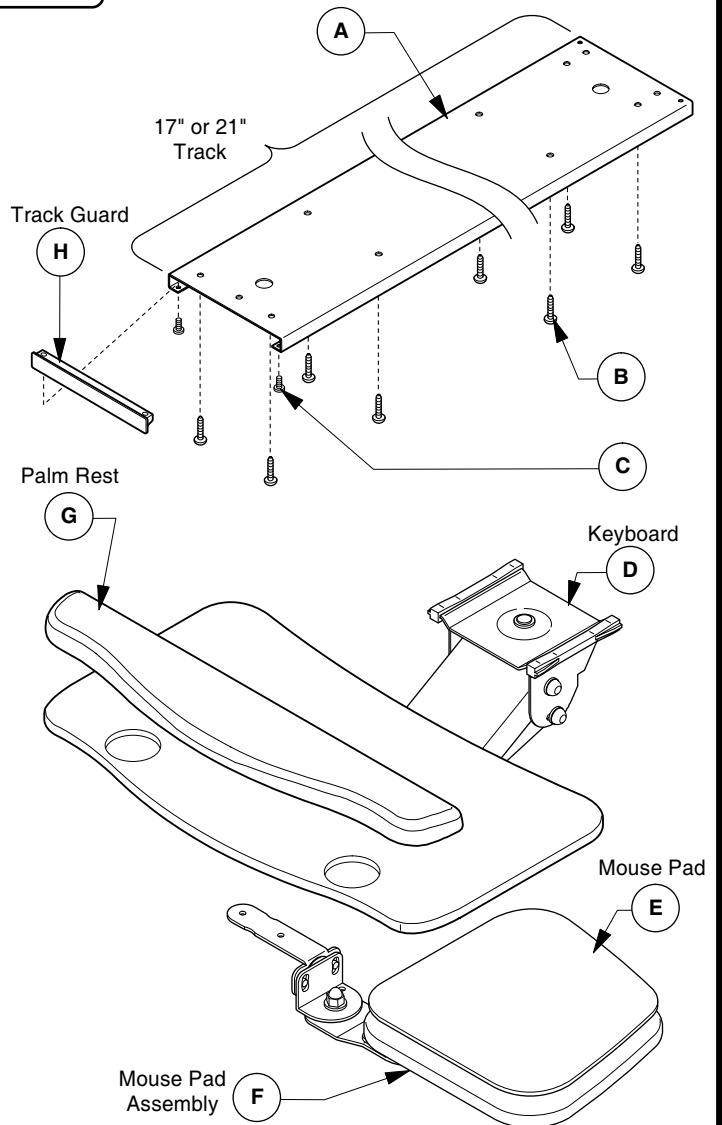
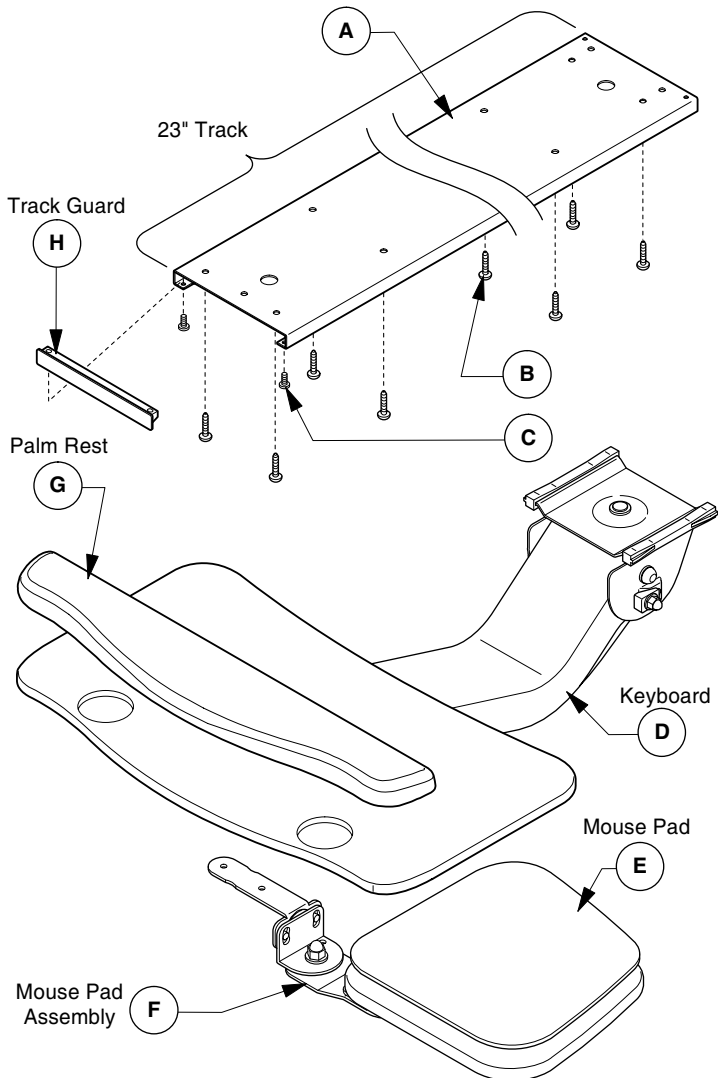
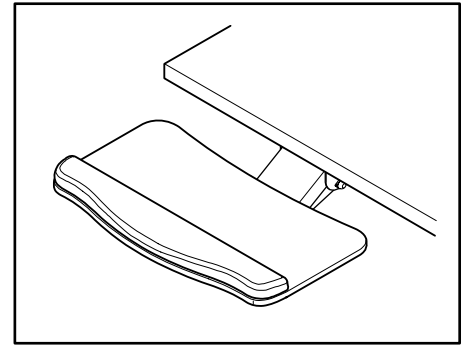
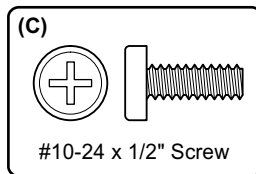
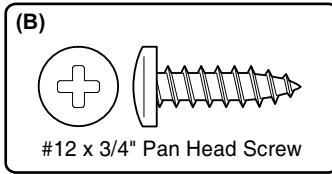
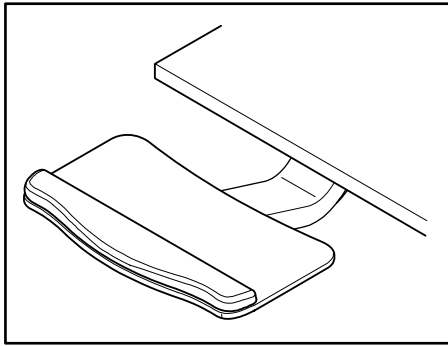
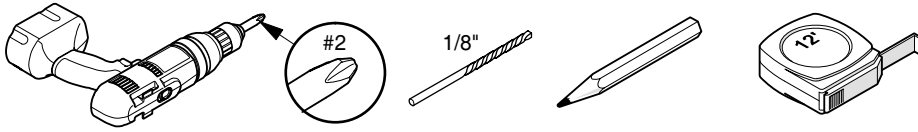

CUSTOMER SERVICE PHONE: 1-800-426-8562

1**Install track (A)***Instale el riel (A)**Installer la voie coulissante (A)*

Note: If worksurface is not pre-drilled, position track (A) 1/2" in from front edge of worksurface. Use holes in track (A) as template and drill 5/8" deep holes.

Nota: Si la superficie de trabajo no tiene agujeros previamente taladrados, coloque el riel (A) a 1,3 cm (1/2 plg.) del borde frontal de la superficie de trabajo. Use los agujeros del riel (A) como plantilla y taladre agujeros de 1,6 (5/8 de plg.) de profundidad.

Remarque : Si la surface de travail n'est pas préalablement perforée, placer la voie coulissante (A) à 13 mm (1/2 po) du bord de la surface de travail. Utiliser les trous de la voie coulissante comme guide et perforer des trous ayant une profondeur de 16 mm (5/8 po).

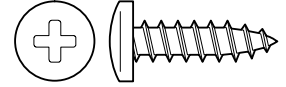
(B)

#12 x 3/4" Pan Head Screw

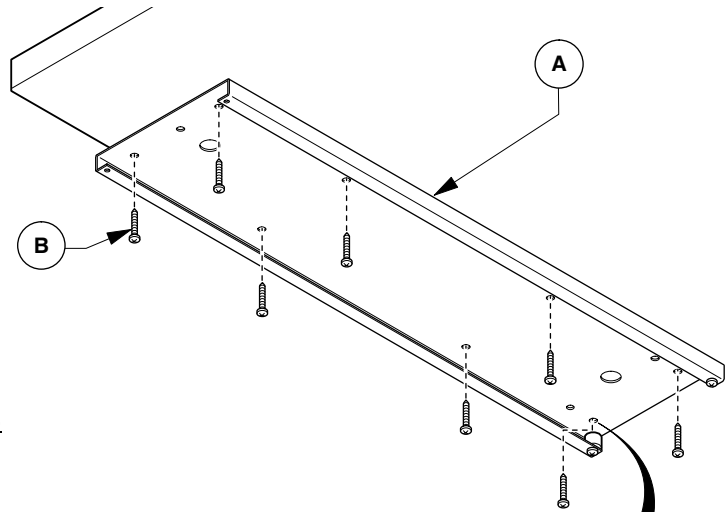
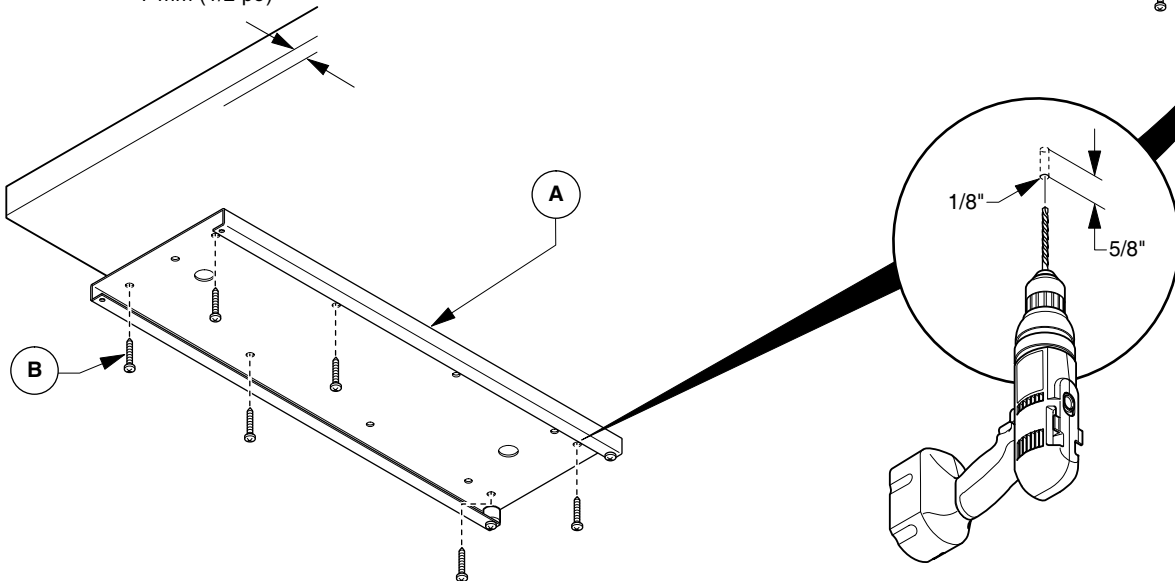
21" OR 23" TRACK INSTALLATION*INSTALACIÓN DEL RIEL DE 53,3 CM (21 plg.) o 58,4 CM (23 plg.)**INSTALLATION D'UNE VOIE COULISSANTE DE 53 CM (21 PO) OU 58 CM (23 PO)*1/2"
7 mm (1/2 po)**17" TRACK INSTALLATION***INSTALACIÓN DEL RIEL DE 43 cm (17 plg.)**INSTALLATION D'UNE VOIE COULISSANTE DE 43 CM (17 PO)*1/2"
7 mm (1/2 po)

CUSTOMER SERVICE PHONE: 1-800-426-8562

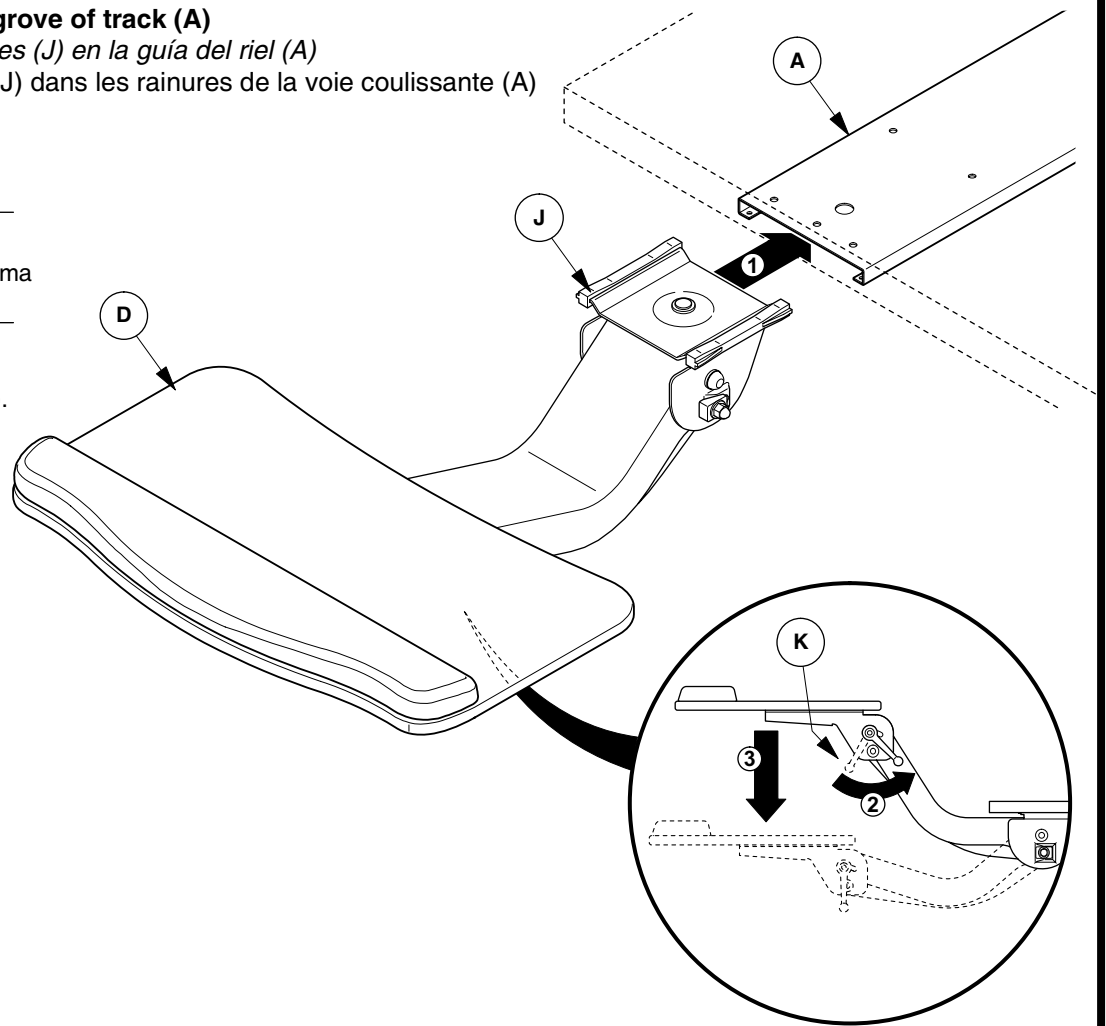
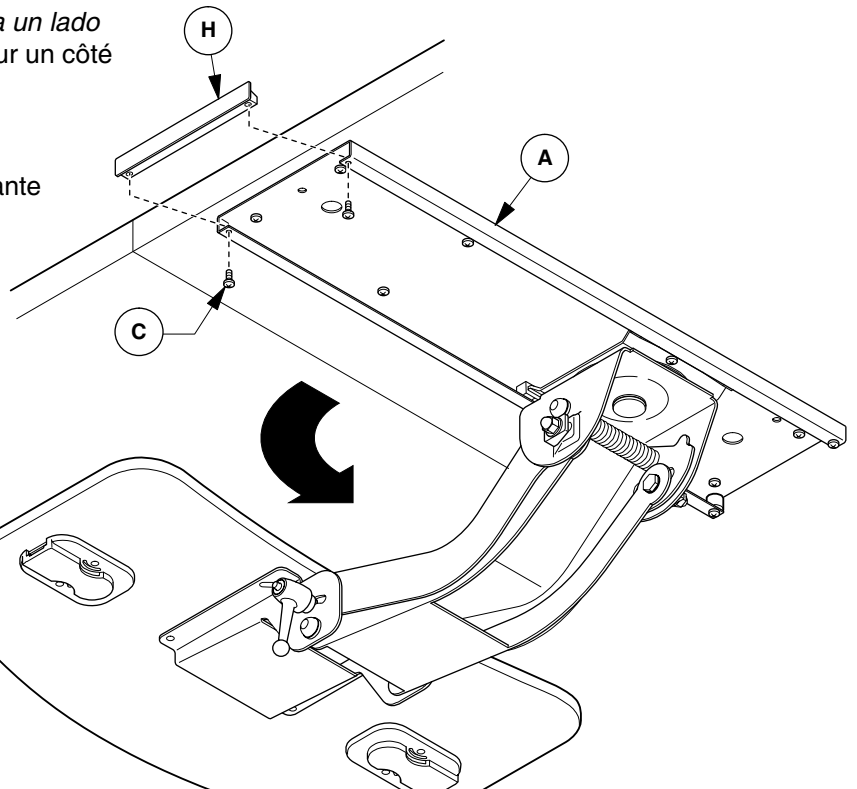
2**Slide glides (J) into groove of track (A)***Deslice los deslizadores (J) en la guía del riel (A)**Insérez les coulisses (J) dans les rainures de la voie coulissante (A)***Note:** If necessary loosen lever (K) to lower keyboard pad (D).**Nota:** Si es necesario, afloje la palanca (K) para bajar la plataforma del teclado (D).**Remarque :** Si nécessaire, desserrez le levier (K) pour abaisser le support de clavier (D).**3****Swivel keyboard pad (D) to one side***Gire la plataforma para teclado (D) hacia un lado**Faites pivoter le support de clavier (D) sur un côté***4****Install track guard (H)***Instale la guarda del riel (H)**Installez la plinthe (H) de la voie coulissante*

(C)

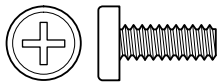

#10-24 x 1/2" Screw

CUSTOMER SERVICE PHONE: 1-800-426-8562

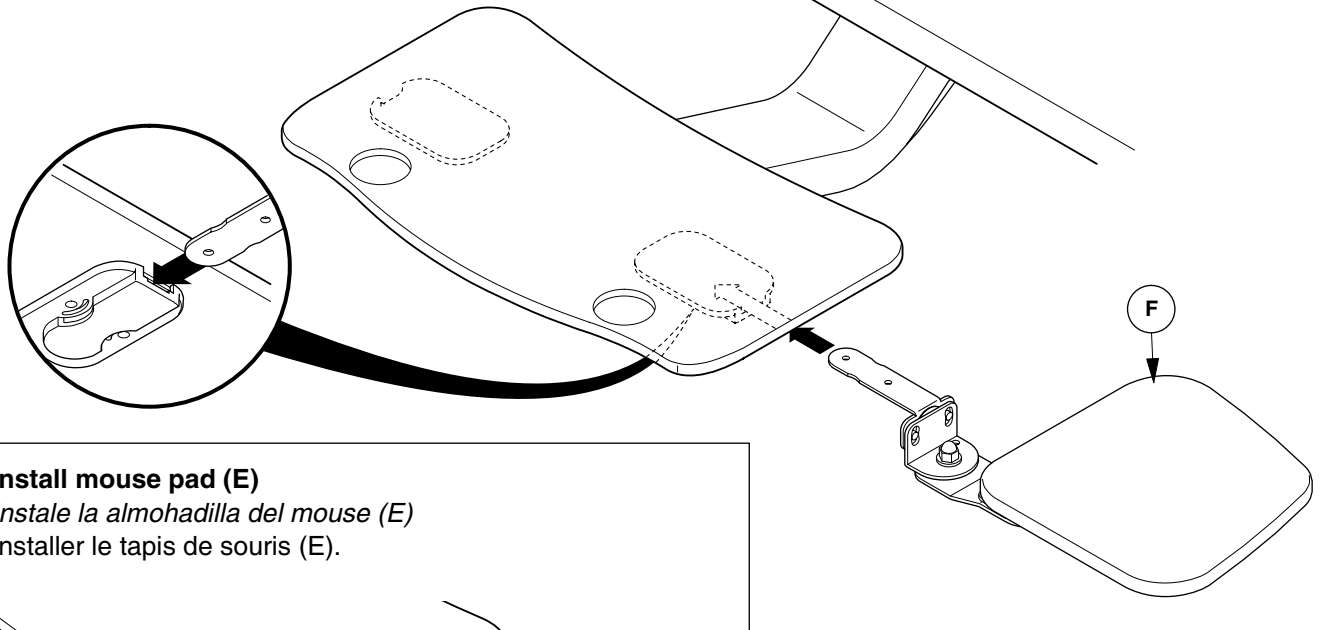
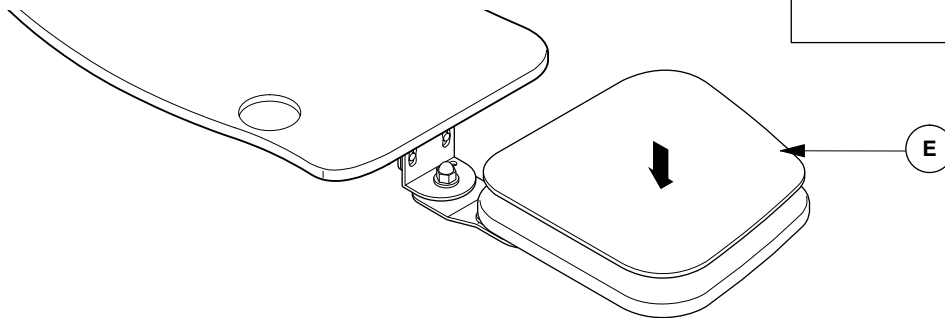
5**Snap mouse pad assembly (F) into place***Encaje en posición la plataforma del mouse (F)**Emboîter le support de la souris (F) à sa place.***6****Install mouse pad (E)***Instale la almohadilla del mouse (E)**Installer le tapis de souris (E).***7****Install palm rest (G)***Instale el apoyo de la palma de la mano (G)**Installer l'appuie-main (G).*

Note: It is preferred that the user will decide if the palm rest (G) should be adhered into permanent position.

Nota: Es preferible que el usuario decida si el apoyo de la palma de la mano (G) debe fijarse en posición permanentemente.

Remarque : Il est préférable que l'utilisateur décide si l'appuie-mains (G) doit être collé de façon permanente.

