

VANCOUVER®
3 Circuit Power
Distribution Assembly
Installation Instructions

Tools Required

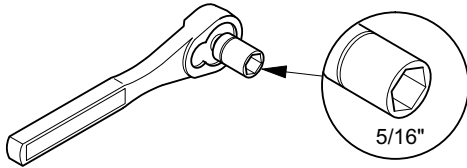

WARNING: Do not electrically interconnect modular power distribution systems powered from two different power feed units. This poses a **SHOCK HAZARD** to service personnel and will cause **RISK OF FIRE** due to excessive circulating currents.

WARNING: All circuit power **MUST REMAIN DISCONNECTED** during any installation or removal of electrical components and raceway covers to avoid **SHOCK HAZARDS**.

NOTE: Connections of this modular power distribution component **MUST** be done by a licensed electrician, who must control the size and loading of each branch circuit. The person or group installing Haworth products is responsible for complying with all applicable building and electrical code requirements.

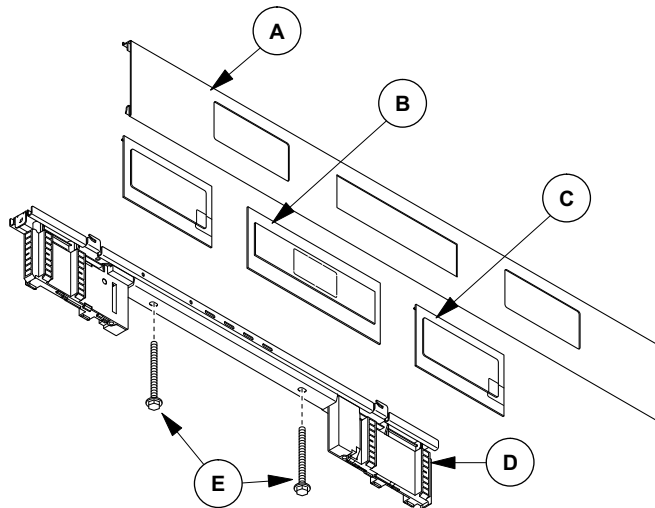
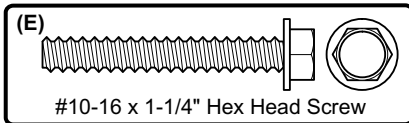

CUSTOMER SERVICE PHONE: 1-800-426-8562

HAWORTH®

E.C.O. No: 305-004

Page: 1 OF 2

Part No: 7021-7598

Rev: B

2

Install PDA (D)

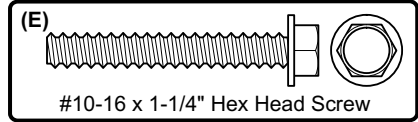

NOTE: PDA is always installed centered.

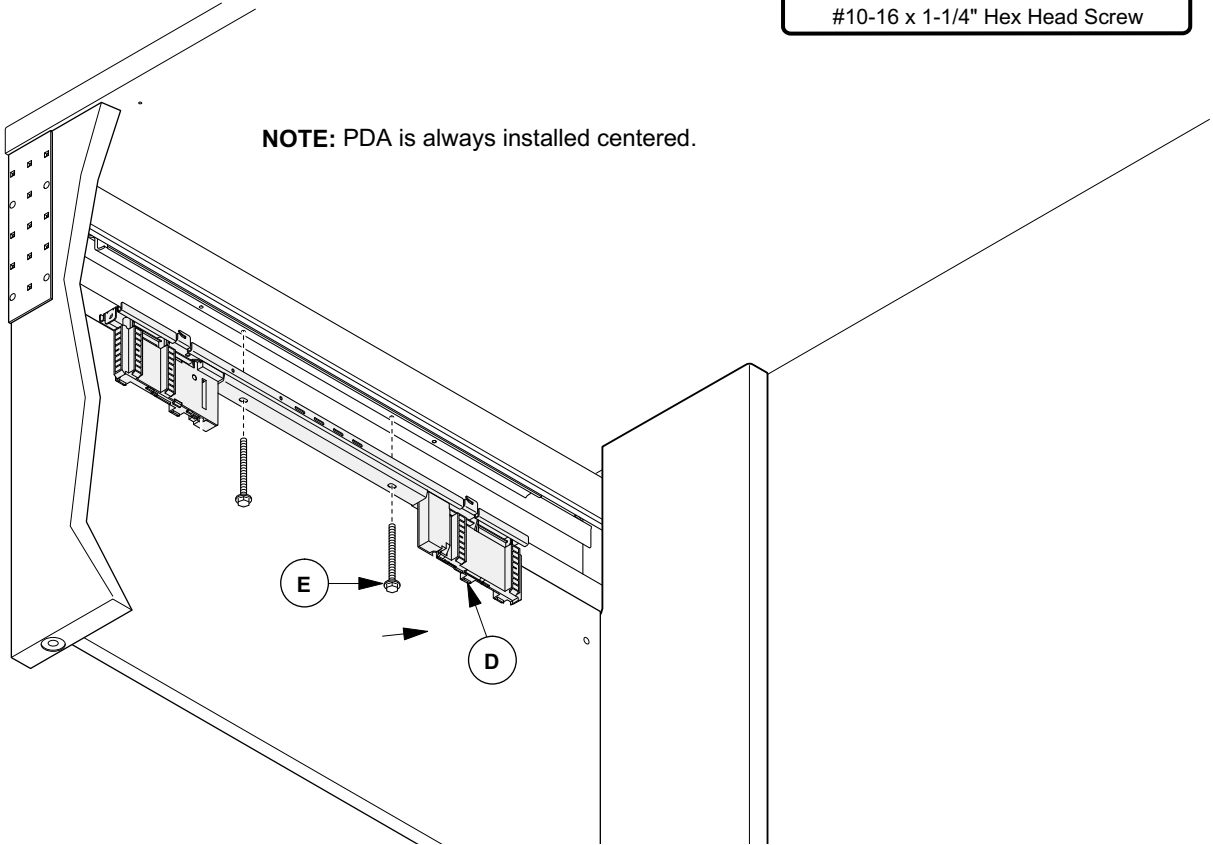

3

Install receptacles, remove access covers(C), and install raceway cover(A)

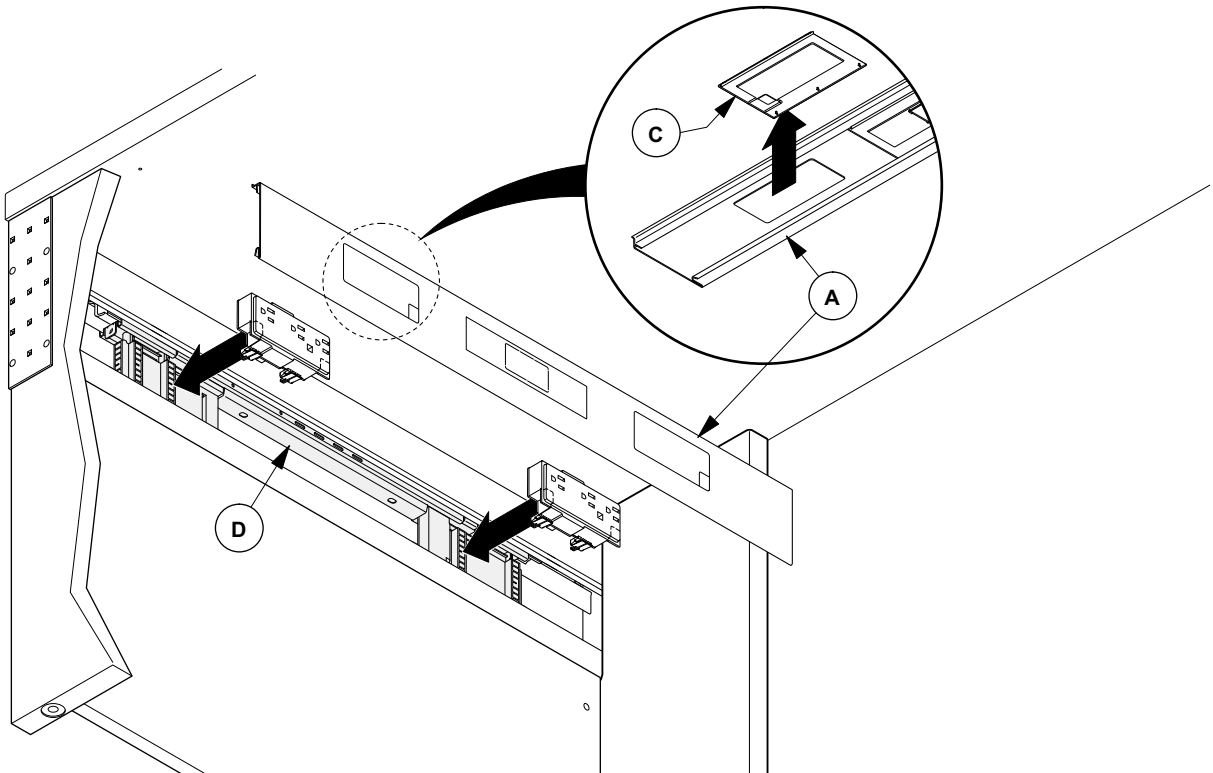

CUSTOMER SERVICE PHONE: 1-800-426-8562