

ADJUSTABLE KEYBOARD AND MOUSE PAD

Installation Instructions

For Models:

AKP-2, AKP-2P, NAK-2, NAK-2P, AKPT-3, AKPT-3P,
NAK-3, NAK-3P, AKPT-4, AKPT-4P, NAK-4,
NAK-4P, HMP-3, and NAKM-3

Tools Required:

- Cross Recess (Phillips) Screwdriver
- Power Driver with 1/8" drill bit (if work surface is not pre-drilled)

Installation Procedure:

1. Mount AKP track to underside of work surface using eight (8) #12 x .63 low root wood screws provided (**Fig. 1**). Track should be positioned so that the pre-installed bumpers are towards the rear of the work surface. If work surface is not pre-drilled, position front edge of track 1/2" in from front edge of work surface and use holes in track as template to drill holes. Drill eight (8) holes, 1/8" dia. x 5/8" deep using care not to drill through top of work surface.
2. Slide arm/tray assembly into track groove (**Fig. 2**).
3. Position track guard in front of track, and install with two (2) #10-24 x .50 type 23 self-tapping screws provided (**Fig. 3**).

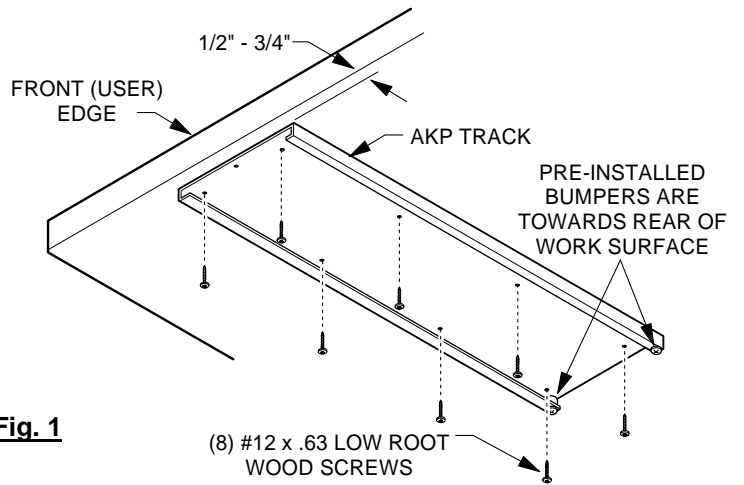

Fig. 1

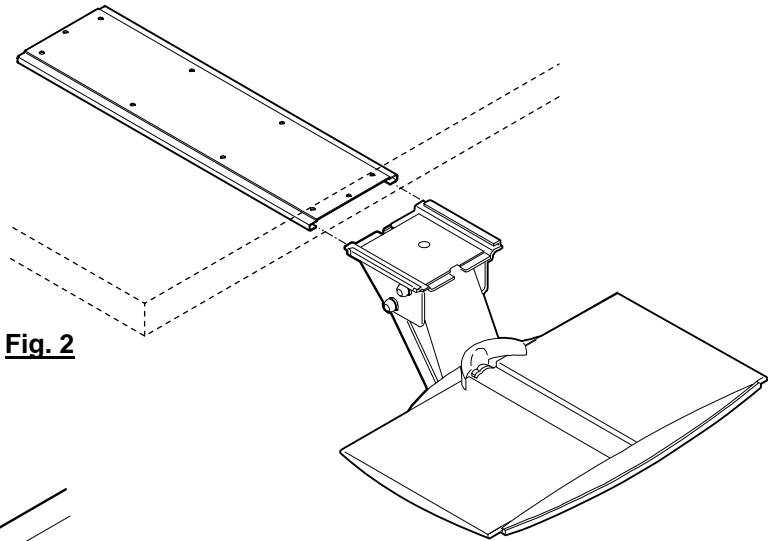

Fig. 2

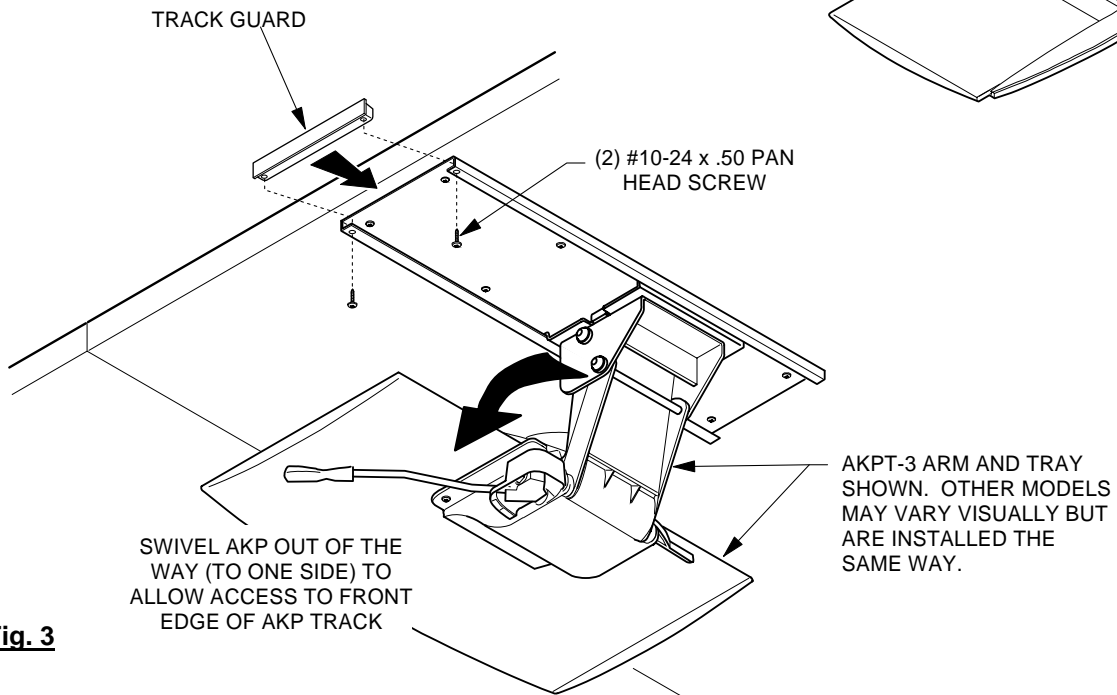

Fig. 3

CUSTOMER SERVICE PHONE: 1-800-426-8562

HAWORTH[®]

E.C.O. No: 251-161

Page: 1 OF 2

Part No: 7021-7210

Rev. C

ADJUSTABLE KEYBOARD AND MOUSE PAD

Type 5 Installation Instructions

For Models:

AKPS-5, AKPS-5P, HMP-2, NAK-5 and NAK-5P

Tools Required:

- Cross Recess (Phillips) Screwdriver
- Power Driver with 1/8" drill bit (if work surface is not pre-drilled)

Installation Procedure:

1. Mount AKP track to underside of work surface using eight (8) #10 x .63 wood screws provided. Install screw with rubber bumper (provided) in center rear hole of track (**Fig. 1**). Do not install screw in center front hole. If work surface is not pre-drilled, position front edge of track 1/2" in from front edge of work surface and use holes in track as template to drill holes. Drill holes, 1/8" dia. x 5/8" deep using care not to drill through top of work surface.
2. Slide arm/tray assembly into track groove (**Fig. 2**).
3. Install screw with rubber bumper (provided) in center front hole of track. Position track guard in front of track and use holes in track guard as a template to mark and drill holes in work surface. Drill two holes, 1/8" dia. x 5/8" deep. Mount track guard to underside of work surface using two (2) #10 x 5/8" panhead, Type AB screws provided.

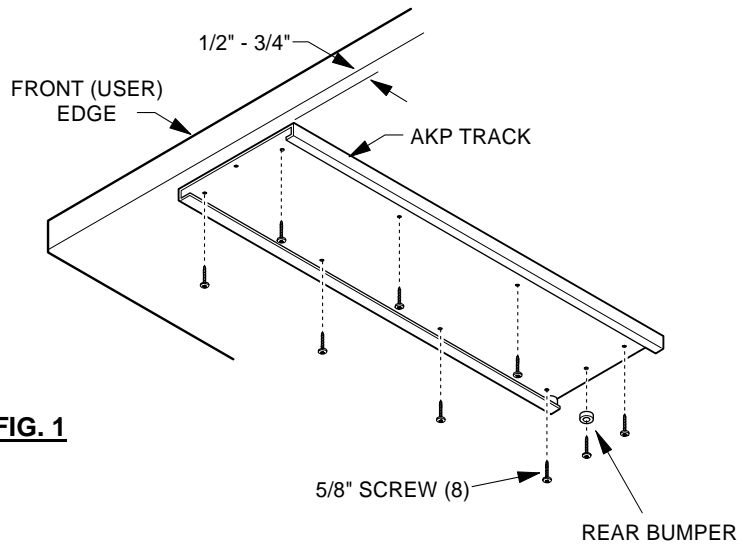

FIG. 1

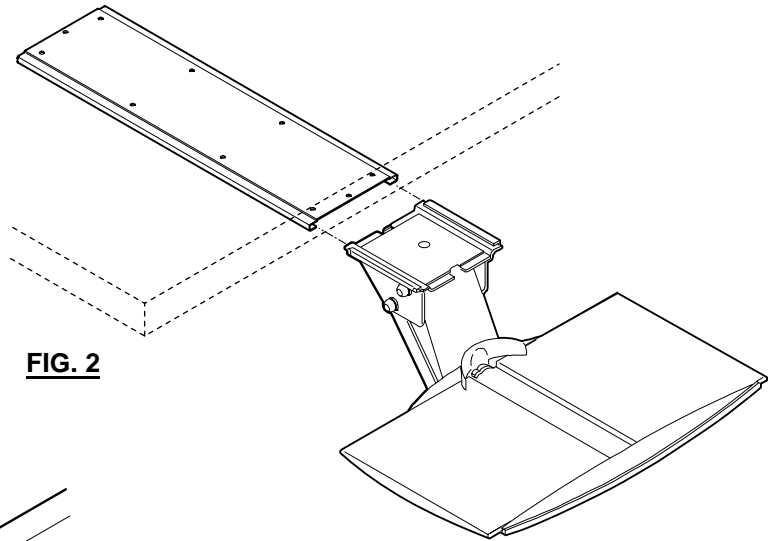

FIG. 2

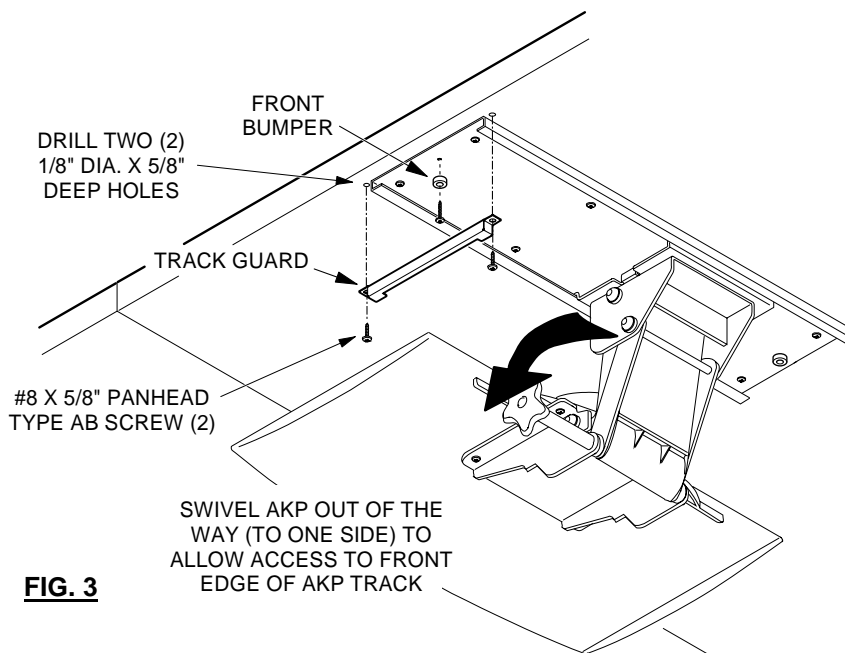

FIG. 3

CUSTOMER SERVICE PHONE: 1-800-426-8562