

**BELONG TOOLS®**  
**Extend Monitor Arm**  
Installation Instructions

**Tools Required**

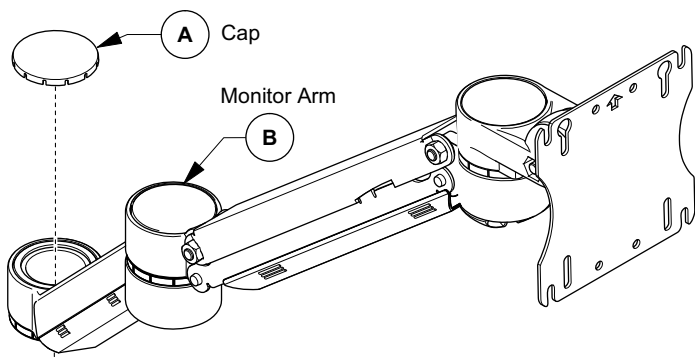

**FOR CLAMP MOUNTING**

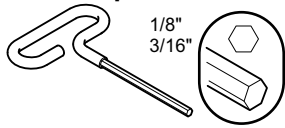
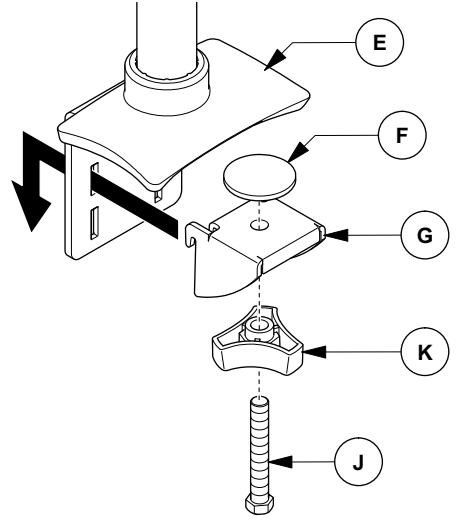

**OR**

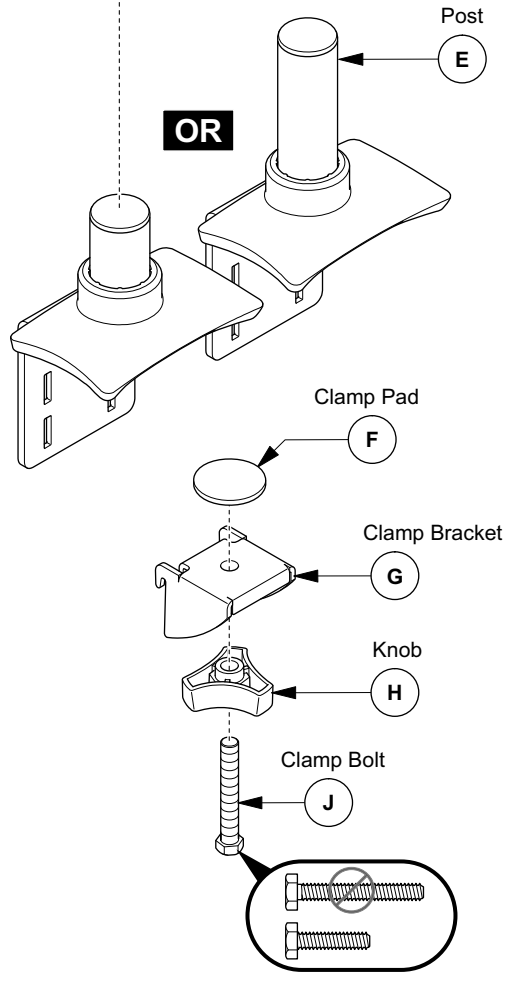

**FOR GROMMET MOUNTING**

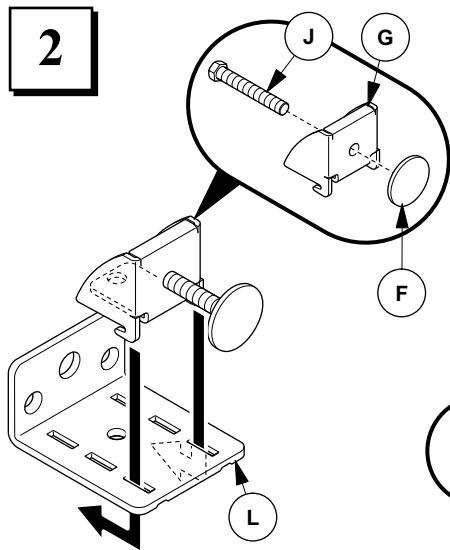
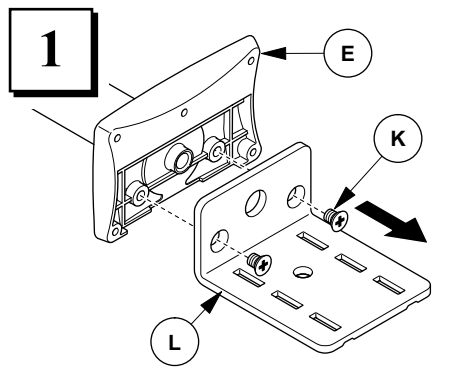

**3**

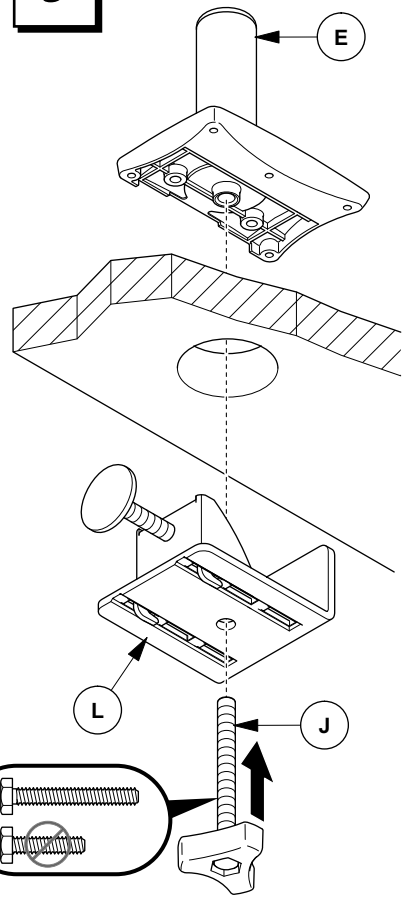

CUSTOMER SERVICE PHONE: 1-800-426-8562

### FOR ARM ASSEMBLY

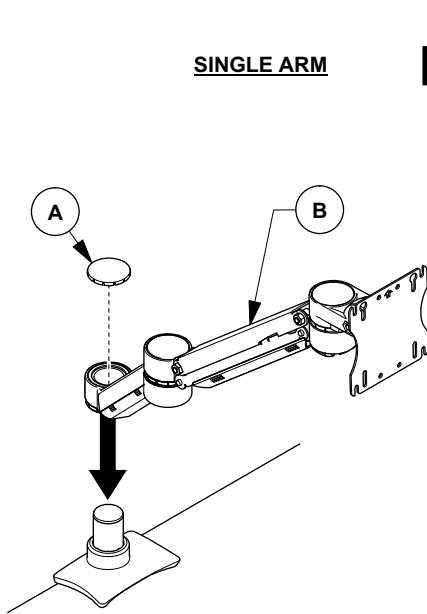

OR

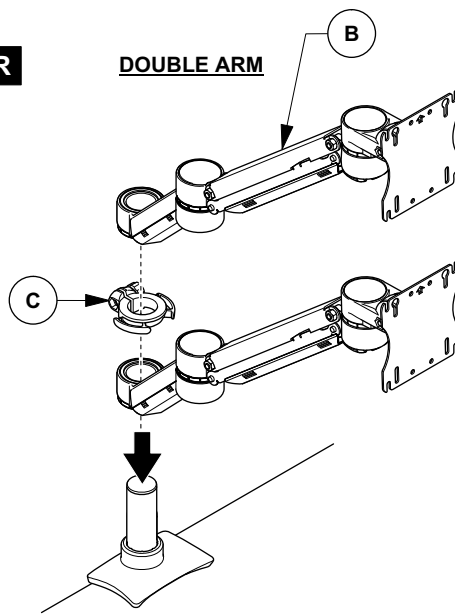

### TENSION ADJUSTMENT

**NOTE:** Do not over tighten set screw (M).

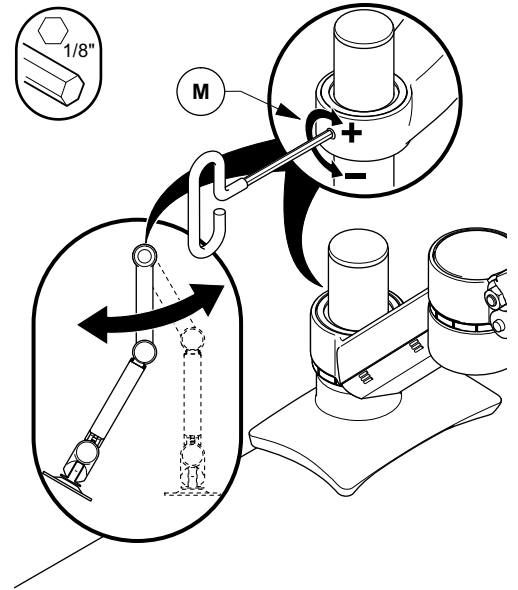

### FOR INITIAL COUNTER BALANCE INSTALLATION

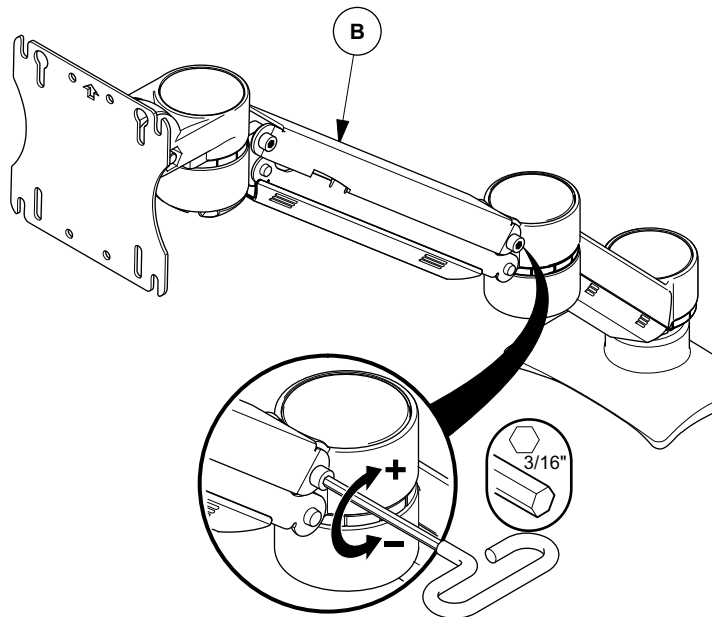

### FOR CABLE MANAGER

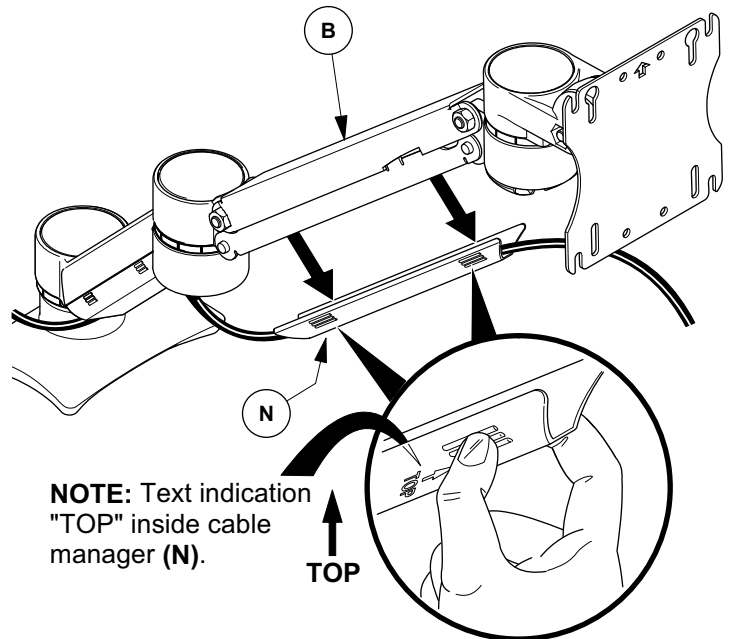

**NOTE:** Text indication "TOP" inside cable manager (N).

CUSTOMER SERVICE PHONE: 1-800-426-8562

**HAWORTH®**

E.C.O. No: 420-080

Page: 2 of 2

Part No: 7029-9845

Rev: A